

# Hand-E-Wave® Installation Instructions, HEW-1S, HEW-1B, HEW-1W, HEW-2S, HEW-2B, HEW-2W, HEW-3S, HEW-3B, HEW-3W and custom variations

## Application

Hand-E-Wave® is a touchless microwave switch designed to provide a DPDT relay normally open or normally closed output when motion is detected within the detection zone. The switch can be configured to provide a 1 to 30 second timed output or a toggle (on/off) output.

## Powering the Unit

Hand-E-Wave is powered with an un-switched 12 to 24VAC/DC. Polarity need not be followed; the switch will work, provided there is a correct voltage across the red & black wires. This input voltage cannot be in series with any connected locking mechanism, such as magnetic locks, etc.

## Operate the Sensor

Move your hand within the detection zone to activate the sensor. The “Hand” symbol will change from Blue to Green and the audio will beep (if audio is enabled) to indicate successful activation of the sensor and relay.

## Wiring

- 1) PWR: 12 to 24VAC/DC (**BLACK**)
  - 2) PWR: 12 to 24VAC/DC (**RED**)
  - 3) Normally Closed: NC Contact (**GRAY**).
  - 4) COM: Relay Common (**Orange**)
  - 5) Normally Open: NO Contact (**BLUE**)
- Double pole contacts;
- 6) Normally Closed: NC Contact (**WHITE**)
  - 7) COM: Relay Common (**YELLOW**)
  - 8) Normally Open: NO Contact (**GREEN**)

## Detection Zone

Hand-E-Wave’s detection zone may be adjusted from 2” to 24” (typical).

Locate the **Detection Zone** potentiometer and rotate with a small standard screwdriver clockwise to increase the sensing field. Rotate counterclockwise to decrease the sensing field. Use a greater range setting for an application where there is little traffic, and precision is not required. Caution should be taken where the door may move into the beam when closing or operating, as this may also activate the sensor. Use a shorter read range for an application where a positive deliberate wave is used to activate.

## Output Mode

**Timed Mode** is recommended for applications where a momentary or timed output is desired. In Timed mode, detection activates the relay for a set period of time (0.5 to 30 seconds). To select timed mode, remove the **Output Mode** jumper (or place the jumper over ONE pin). To **SET** the output time, locate the **Output Time** potentiometer and rotate clockwise to increase the output time (up to 30 seconds). Rotate counterclockwise to decrease the output time. To trigger an automatic door opener, set the output time to 1 second.

**Toggle Mode** is recommended for ON/OFF switch applications. In toggle mode, detection activates the relay and a second detection deactivates the relay. To select toggle mode, place the jumper over **BOTH** pins of the **Output Mode**.

## Audio Control

Hand-E-Wave’s audio feedback occurs when motion is detected within the detection zone. Audio can be enabled or disabled. To enable audio feedback, remove the **Audio Control** jumper (or place the jumper over ONE pin). To disable audio feedback, place the jumper over **BOTH** pins of the **Audio Control**.

## Mounting

**HEW-1** is designed for narrow or mullion mount applications. For recessed installation, use template provided to mark and remove material. For surface mount installation, an optional spacer ring (SR-1) is available.

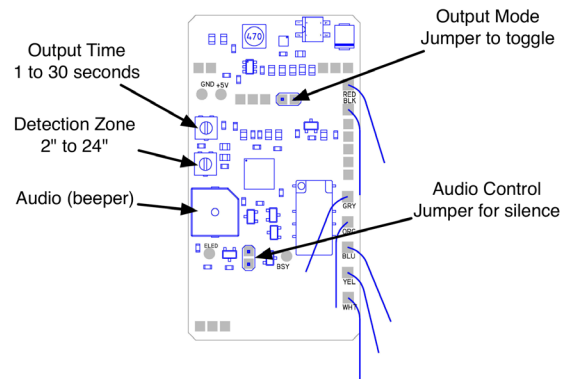

**HEW-2** is designed to mount to a standard U.S. Single Gang switchbox. An optional extension back box (BAK BOX-SGE) is available for surface mount installation.

**HEW-3** is designed to mount to a standard U.S. Double Gang switch box. An optional extension back box (BAK BOX-DGE) is available for surface mount installation.

### TYPICAL INSTALLATIONS

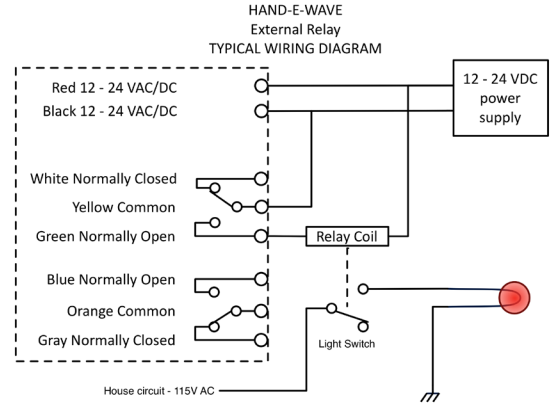
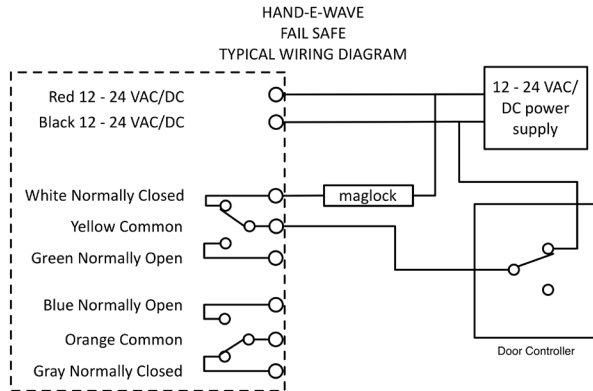

There are two sets of relay contacts that may be used. The normally closed contacts, the white wire to the yellow wire, would be in series with a normally powered locking mechanism, such as a magnetic door lock. This would also be in series with the controller applying locking power. The normally open contacts, the orange to the blue wires, could be used to apply a “request to exit” or “REX” signal to the controller, which would then apply power to unlock. Since both sets of contacts are not normally used at the same installation, the set that is not being used as described may be used to indicate that the HEW has been activated, to a control panel or security system.

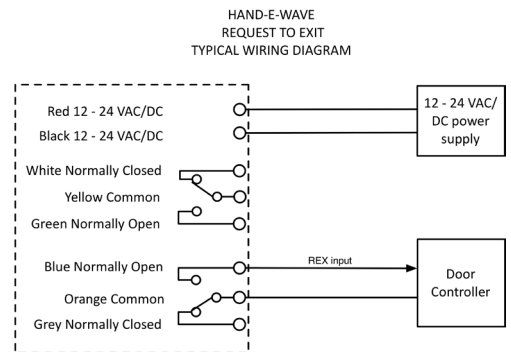

### Regulatory Compliance - FCC

#### End Product Labeling

The next assembly should have instructions and a label that refers to the manufacturer FCC ID: UXS-IPM165 & Canada IC: 6902A-IPM165 for all models of the Hand-E-Wave. This device HEW has been tested and approved to be compliant with Part 15.245 of the FCC Rules and with RSS-210 Issue 7 of Industry Canada. Operation is subject to the following conditions:

1. This device may not cause harmful interferences, and
2. This device must accept any interference received, including interference that may cause undesired operation.

This equipment has been tested and found to comply with the limits for a Class B digital device, pursuant to part 15 of the FCC Rules. These limits are designed to provide reasonable protection against harmful interference in a residential installation. This equipment generates, uses and can radiate radio frequency energy and, if not installed and used in accordance with the instructions, may cause harmful interference to radio communications. However, there is no guarantee that interference will not occur in a particular installation. If this equipment does cause harmful interference to radio or television reception, which can be determined by turning the equipment on and off, the user is encouraged to correct the interference by one or more of the following measures:

- Reorient or relocate the receiving antenna
- Increase the separation between the equipment and receiver
- Connect the equipment into an outlet on a circuit different from that to which the receiver is connected
- Consult the dealer or an experienced radio/TV technician for help

This device has been tested and approved to comply with Part 15B unintentional radiator requirements. The antenna of the module may not be removed, replaced nor modified. The antenna must not be co-located or operating in conjunction with any other antenna or transmitter. No additional antenna must be used. This device may not cause harmful interferences, and this device must accept any interference received, including interference that may cause undesired operation.

### UL

UL 294 Performance Levels: Access Control Line Security I, Destructive Attack Level I, Endurance Level IV, Standby Power Level I.

**WARNING:** CHANGES OR MODIFICATIONS TO THIS EQUIPMENT NOT EXPRESSLY APPROVED BY ESSEX MAY VOID THE FCC AUTHORIZATION TO OPERATE THIS EQUIPMENT.

Hand-E-Wave® is a registered trademark of Essex Electronics, Inc

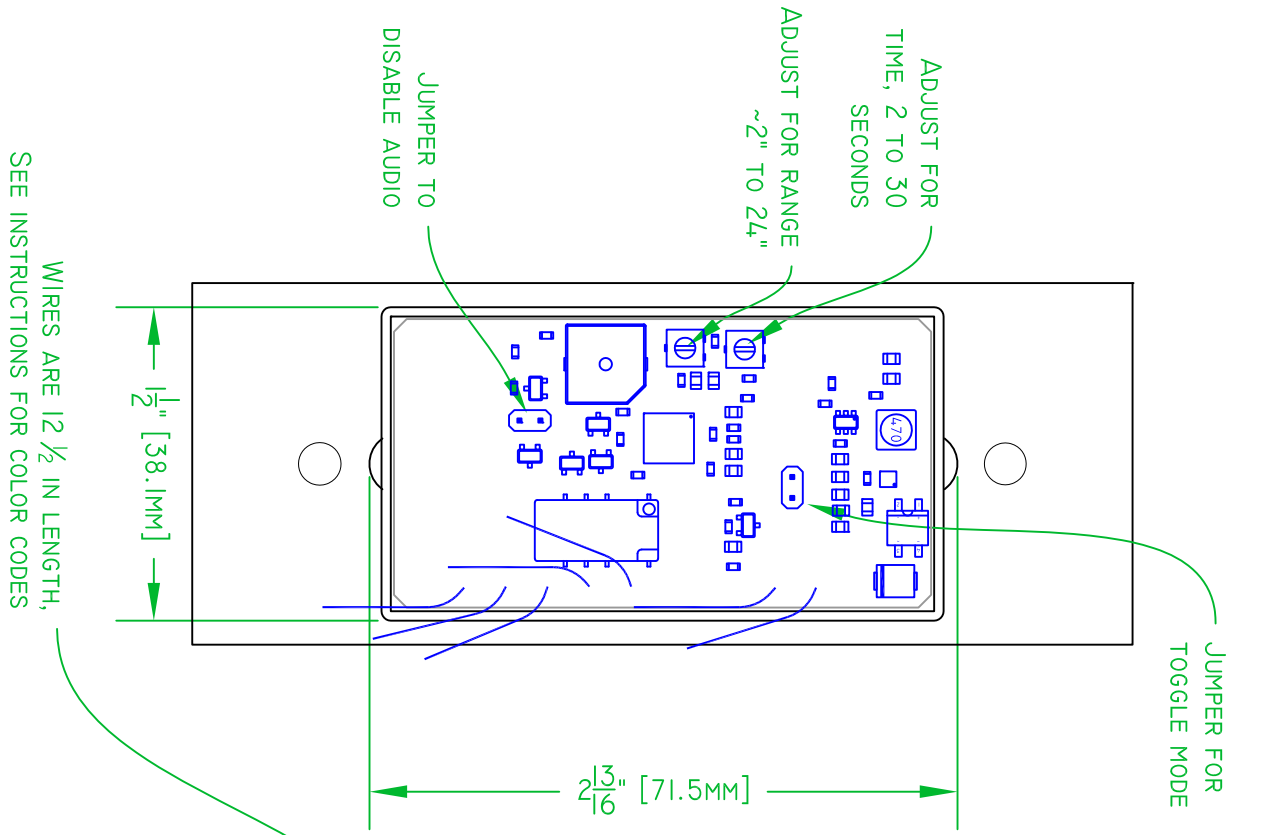

WIRES ARE 12 1/2 IN LENGTH, SEE INSTRUCTIONS FOR COLOR CODES

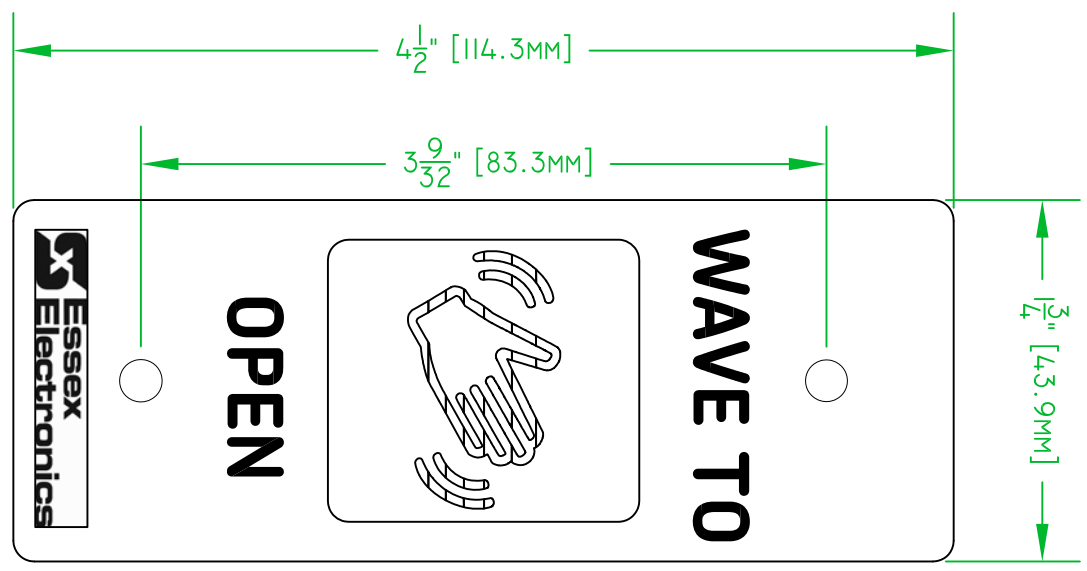
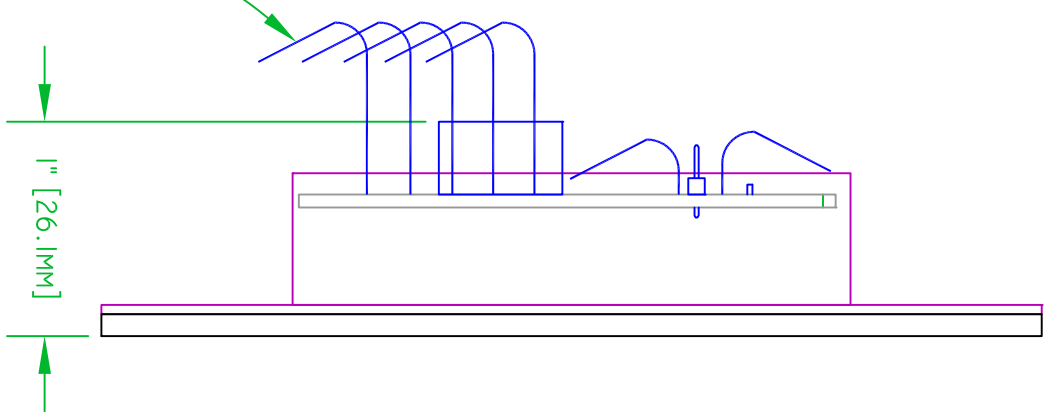

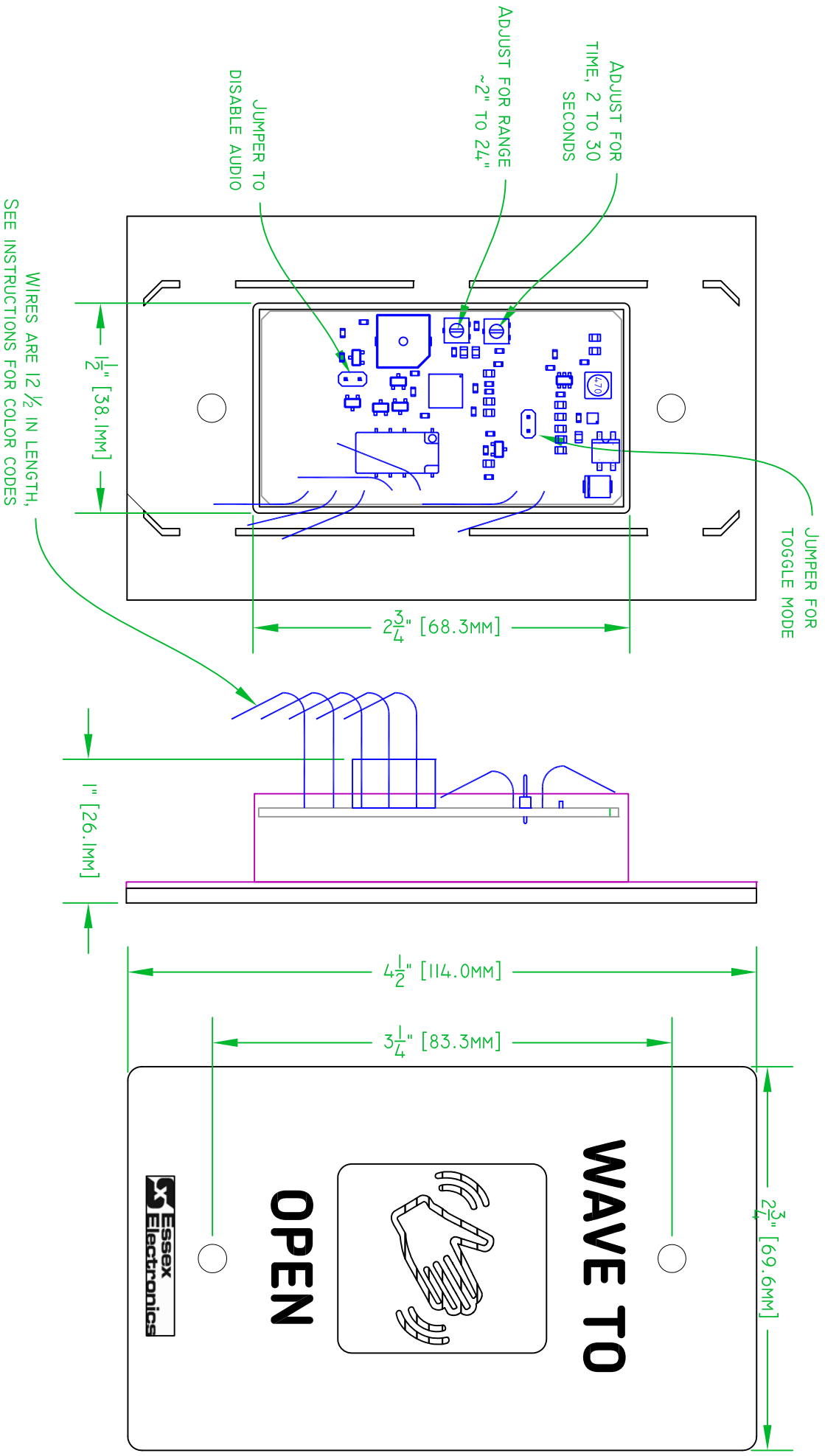

WIRES ARE 12 1/2 IN LENGTH. SEE INSTRUCTIONS FOR COLOR CODES.

